



*complete*



## Comfort and efficiency wrapped up in one sleek package.

When it comes to your home's indoor climate, you shouldn't have to choose between comfortable temperatures and energy savings. Lennox® packaged units offer remarkably efficient performance, while delivering exceptional comfort year round. And with a streamlined cabinet design, these units can be easily installed in almost any residential setting. Whether you choose the gas/electric 15GCSX, the 15CHAX cooling system or the 15CHPX heat pump, it's easy to see good things come in Lennox packages.

Energy ratings as high as 15.00 SEER\* and 8.00 HSPF\*\* can help lower your utility bills.

\*Seasonal Energy Efficiency Ratio  
\*\*Heating Seasonal Performance Factor



*designed for quiet operation and total*

*comfort*

### Quality you can trust

Packaged units are an ideal solution when indoor space is at a premium. These units have the same components you would find in a typical split system, but are engineered to contain them all in one streamlined cabinet. Units are installed on your rooftop or on the ground outside your home or office, connecting to your ductwork through a secure opening in the outside wall. This makes the units easy to install and service and leaves you with maximum usable indoor space—all while providing ultimate comfort.

### A star performer

All packaged units in the Dave Lennox Signature® Collection are ENERGY STAR® qualified to help you save energy and possibly lower your utility bills. With efficiency ratings of up to 15.00 SEER, these packaged units are designed to keep you comfortable all year long, while saving energy costs every month. The 15CHPX offers up to 8.00 HSPF (Heating Seasonal Performance Factor) and the 15GCSX delivers up to 78% AFUE (Annual Fuel Utilization Efficiency).

### Enjoy cleaner air in comfort

These packaged units are IAQ-ready, so they can easily be optimized for improved indoor air quality. For example, the Pure Air™ air purification system from Lennox cleans the air in your home better than any other single system you can buy—and it simply mounts inside your packaged unit.



15GCSX  
15CHAX  
15CHPX

Remarkably  
efficient  
packaged  
units



# Smart technologies so you can relax in comfort.

## Comfort you can feel, not hear

---

Every Lennox® packaged unit is engineered to keep sounds at a minimum. All three models in the Dave Lennox *Signature*® Collection feature an internally mounted outdoor fan to significantly reduce vibrations and operating sound. The 15GCSX is able to deliver additional quiet comfort with two-stage heating and variable speed air-handling technology.

## Built for years of reliable use

---

Every Lennox packaged unit is constructed of heavy-gauge, pre-painted steel and tested in the most extreme environments to ensure maximum durability.

## Peace-of-mind protection

---

The 15CHPX packaged heat pump and 15CHAX cooling system both come with a 10-year limited warranty on the compressor and a 10-year limited warranty on remaining covered components. The 15GCSX packaged gas/electric unit comes with a 20-year limited warranty on the heat exchanger and a 10-year limited warranty on the compressor and remaining covered components.\*



\*Applies to residential applications only. See actual warranty certificate for details.

## 15CHPX/15CHAX



**Internally Mounted Outdoor Fan** – Significantly reduces operating sound (vibrations) and allows easier servicing

**Dependable Scroll Compressor** – Provides reliable and efficient operation

**Enhanced Coil Guard** – Protects the condenser coil, maintaining the efficiency of the unit

**Easy-Access Control Panel** – Allows faster servicing

**All-Metal Cabinet with Integrated Base** – Offers long-term durability, even in most harsh environments

**Variable Speed Blower Motor** – Precisely controls the flow of heated and cooled air for improved comfort

**IAQ-Ready Design** – Can be easily equipped with internally mounted PureAir™ air purification system for improved indoor air quality

Up to 15.00 SEER  
ENERGY STAR®  
qualified

### Dave Lennox Signature® Collection 15CHPX Specifications

Model	024	030	036	042	048	060
SEER	15.00	14.00	14.00	15.00	14.00	14.00
HSPF	8.00	8.00	8.00	8.00	8.00	8.00
Dimensions HxWxD (in) HxWxD (mm)	34-1/4 x 65-3/8 x 36-1/2 870 x 1661 x 927	34-1/4 x 65-3/8 x 36-1/2 870 x 1661 x 927	34-1/4 x 65-3/8 x 36-1/2 870 x 1661 x 927	38-1/4 x 75 x 46 972 x 1905 x 1168	38-1/4 x 75 x 46 972 x 1905 x 1168	38-1/4 x 75 x 46 972 x 1905 x 1168

### Dave Lennox Signature Collection 15CHAX Specifications

Model	024	030	036	042	048	060
SEER	14.50	14.00	15.00	14.50	14.00	14.00
Dimensions HxWxD (in) HxWxD (mm)	34-1/4 x 65-3/8 x 36-1/2 870 x 1661 x 927	34-1/4 x 65-3/8 x 36-1/2 870 x 1661 x 927	34-1/4 x 65-3/8 x 36-1/2 870 x 1661 x 927	38-1/4 x 75 x 46 972 x 1905 x 1168	38-1/4 x 75 x 46 972 x 1905 x 1168	38-1/4 x 75 x 46 972 x 1905 x 1168

**Note:** Due to Lennox' ongoing commitment to quality, all specifications, ratings and dimensions are subject to change without notice.



## 15GCSX

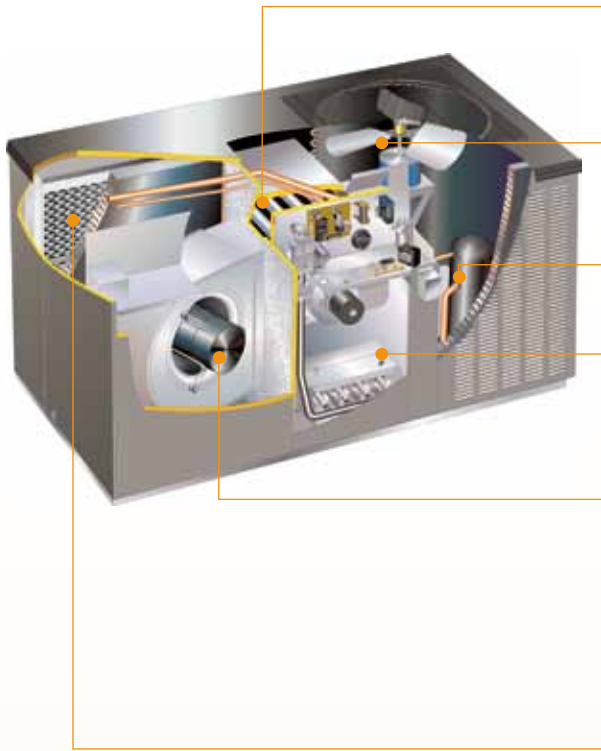

**Tubular Heat Exchanger** – Provides excellent heat transfer and superior airflow control for years of efficient, reliable operation

**Internally Mounted Outdoor Fan** – Significantly reduces operating sound (vibrations) and allows easier servicing

**Dependable Scroll Compressor** – Provides reliable and efficient operation

**Easy-Access Control Panel** – Allows faster servicing

**Two-Stage Heating** – Runs at low-stage heat most of the time, providing high-efficiency performance

**Variable Speed Blower Motor** – Precisely controls the flow of heated and cooled air for improved comfort

**Lennox® System Operations Monitor** – Continuously monitors system operation for added reliability and faster, more accurate servicing

**IAQ-Ready Design** – Can be easily equipped with internally mounted PureAir™ air purification system for improved indoor air quality

Up to 15.00 SEER  
and 78% AFUE

### Dave Lennox Signature® Collection 15GCSX Specifications

Model	024	030	036	042	048	060
AFUE	78%	78%	78%	78%	78%	78%
SEER	14.50	14.00	15.00	14.50	14.00	14.00
<b>Dimensions</b>						
HxWxD (in)	34-1/4 x 65-3/8 x 36-1/2	34-1/4 x 65-3/8 x 36-1/2	34-1/4 x 65-3/8 x 36-1/2	38-1/4 x 75 x 46	38-1/4 x 75 x 46	38-1/4 x 75 x 46
HxWxD (mm)	870 x 1661 x 927	870 x 1661 x 927	870 x 1661 x 927	972 x 1905 x 1168	972 x 1905 x 1168	972 x 1905 x 1168

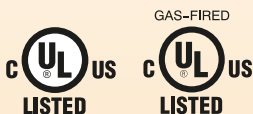

# A brand that delivers beyond basic comfort.



Lennox has always been a leading global name in home comfort. Today, we're pushing beyond the traditional parameters of comfort by setting the pace for environmentally responsible climate control.

So, when you choose Lennox, you can feel good knowing you're getting the best. And when you choose the Dave Lennox *Signature*® Collection, you're getting the best of the best. From the world's first riveted-steel furnace to the first solar-assisted heat pump, products from the Dave Lennox *Signature* Collection are engineered to deliver innovation beyond measure.

## Dealers you can count on

---

You can trust Lennox Dealers to design the right system for your home, install it properly and keep it running perfectly for many years to come. Because Lennox has more than 6,000 dealers throughout North America, you can rest assured there's a dealer near you.



For a complete list of the registered and common law trademarks owned by Lennox Industries Inc., please visit [www.lennox.com](http://www.lennox.com).